Design and Mechanical Model Analysis of Magnetorheological Fluid Damper

Wentao Liu, Yiping Luo, Bin Yang, Wen Lu

Automotive Department, Shanghai University of Engineering Science, Shanghai, China

Email address:

1392165995@qq.com (Wentao Liu)

To cite this article:

Wentao Liu, Yiping Luo, Bin Yang, Wen Lu. Design and Mechanical Model Analysis of Magnetorheological Fluid Damper. *American Journal of Mechanics and Applications*. Vol. 4, No. 1, 2016, pp. 15-19. doi: 10.11648/j.ajma.20160401.13

Received: October 11, 2016; **Accepted:** October 21, 2016; **Published:** November 16, 2016

Abstract: Compared with the general damper, the MR fluid damper has the advantages of adjustable damping, large damping force and intelligence. Magneto rheological fluid damper is a unique role in the study of vibration, shock absorption, and tactile feedback. When the semi-active vibration control of the structure is carried out by the MR damper, the more accurate mechanical model of the damper is one of the key factors to achieve the better control effect of the MR damper. In this paper, the mechanical model of several magneto rheological fluid dampers is analyzed, and the characteristics are analyzed, and the design of MR fluid damper is performed on the basis of the analysis results.

Keywords: Magnetorheological Fluid, MRF Damper, Bouc-Wen Model

1. Introduction

As a kind of intelligent material, magneto rheological fluid has the advantages of rapid change, continuous, high efficiency, safety, reliability, etc.. Application in vibration control, hydraulic devices, clutches, brakes, seals, polishing devices, flexible fixture and other mechanical structures, all show its strong potential. Compared with other devices, magneto rheological fluid devices have the following advantages:

- (1) Control and adjustment of the continuous change of performance, can be accurate real-time control;
- (2) The main working components are not easy to wear and long working life;
- (3) The structure is simple, the work is soft, the noise is low, and the response speed is fast;
- (4) The need to control the low energy consumption, easy to combine with computer technology, intelligent control form.

Therefore, using magnetorheological effect to the development of new products and to some products compared to, in performance, manufacturing, use and prices have obvious advantages and competitiveness in the market, has been applied in the fields of aviation, aerospace, machinery, automobile, precision machining, control.

Magnetorheological fluid damper has small volume, low

power consumption, damping force, wide dynamic range, frequency response characteristics of wide applicable range and high, especially it can produce the best damping force according to the vibration characteristics of the system and in smart structure fields has wide application prospect, is one of the hot topics in the research, both at home and abroad also gradually attention. In foreign countries, MR (magnetic fluid variants) semi-active damping shock absorber research has been the strong support of major companies such as Ford, general motors and other countries, have invested heavily in this area of research.

2. MR Damper Mechanical Model Analysis

When using MR damper to control the semi-active vibration, it is one of the key factors to establish a more accurate mechanical model of the damper to achieve a good control effect on the structure of MR damper. However, the dynamic constitutive relation of MR fluid is very complicated, and it is difficult to use the theory of rheological mechanics. Therefore, it is an ideal method to establish a simple mechanical model suitable for engineering application, according to the results of MR damper dynamic test. This mechanical model not only can reflect the basic dynamic

characteristics of the MR damper, but also provide accurate and reliable theoretical prediction of the dynamic response of the system.

2.1. Bingham Viscoplastic Model and Its Characteristics

In 1987, Stanway et al proposed a mechanical model based on the current variant of the Bingham model, Shames and so on to fit the performance of MR damper. Bingham model is the earliest, simplest and most commonly used model for predicting the response of magneto rheological damping system. The magnetorheological fluid is considered as a material with yield stress, and when the shear stress reaches the yield stress, the flow of the MR fluid is shear flow. The shear stress is linear with the shear rate, as shown in figure 1. Mechanical model of damper can be equivalent to a Coulomb friction damper and a linear viscous damper to represent, as shown in Figure 2.

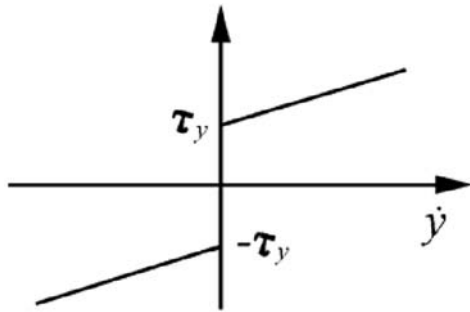

Fig. 1. The shear stress is linear with the shear rate.

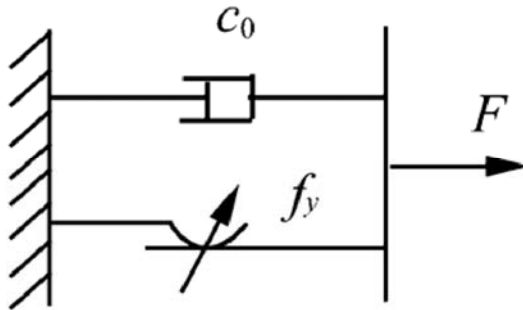

Fig. 2. Linear viscous damper to represent.

The yield stress is a function of the magnetic field strength, which is tested by the shear stress test of the MR fluid. The mathematical relationship between stress and shear rate is:

$$\tau = \tau_y(H) \text{sgn}(\gamma) + \eta \dot{\gamma} \quad (1)$$

$\tau_y(H)$ represents yield stress of magnetorheological fluids. It is a function of the strength of the magnetic field. η represents viscosity of magnetorheological fluids. γ represents shear strain rate of magneto rheological fluid.

The damper's damping force formula is:

$$F = f_y \text{sgn}(\dot{x}) + c_0 \dot{x} \quad (2)$$

f_y represents yield stress of damper; x represents displacement of the damper piston rod; \dot{x} represents damper piston cylinder relative velocity; c_0 represents viscous

damping coefficient after yield of magneto rheological fluid.

The advantage of Bingham model is simple, clear and easy to understand and analyze. One of the main characteristics of MR fluids: the flow of a fluid is shear flow. The main work in the retroflexion of magnetorheological fluid. The key parameter is the dynamic yield stress, which can be used to fit the relationship between the damping force displacement curve of the MR damper. The disadvantage is that it can not describe the damping force velocity nonlinearity, so it is only suitable for the analysis of the reaction not applicable to control analysis.

2.2. Bingham Visco Elastic Model and Its Characteristics

1991 Gamoto of electrorheological fluid research in improved Bingham visco plastic model, is proposed in this paper stuck on the Bingham plastic model based on the series in the form of a standard linear solid formation of the viscoelastic - plastic model, including Bingham visco plastic model of viscoelastic plastic model is established, as shown in Figure 3.

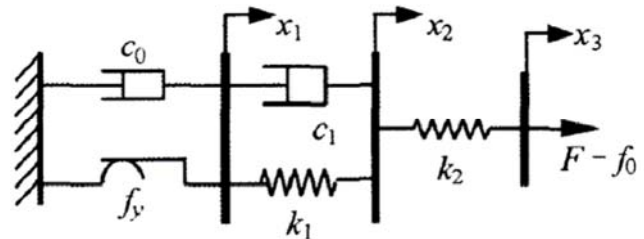

Fig. 3. Bingham model.

Damper damping force is:

$$F = k_1(x_2 - x_1) + c_1(\dot{x}_2 - \dot{x}_1) \quad (3)$$

$$= c_0 \dot{x}_1 + f_y \text{sgn}(\dot{x}) = k_2(x_3 - x_2) \quad (4)$$

$$|F| > f_y \quad (4)$$

$$F = k_1(x_2 - x_1) + c_2 \dot{x}_2 \quad |F| < f_y \quad (5)$$

x represents displacement of the damper piston rod; c_0 represents damping coefficient; parameters k_1, k_2, c_1 linear solid material;

The model is simple in form and clear in meaning, and overcomes the shortcomings of Bingham model, which can reflect the hysteresis characteristics of magneto rheological fluids. The nonlinear characteristic of the damping force velocity curve in the zero velocity time sliding continuous and close to the test, the force displacement relation of the MR damper is well described. However, it can not be well fitted to the MR damper at low speed, the restoring force attenuation phenomenon, and the use of the absolute value function, increased the difficulty of the use of the model.

2.3. Bouc-Wen Model and Its Characteristics

In 1997, Wen proposed the Bouc-Wen model, as shown in Figure 4.

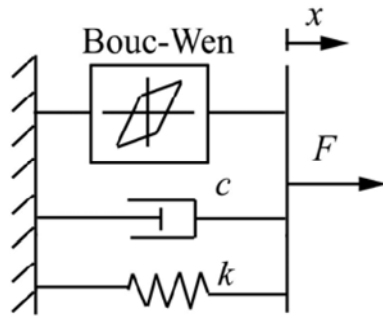

Fig. 4. Bouc-Wen model.

Damping force of the damper is:

$$F = k_0(x - x_0) + c_0\dot{x} + az \tag{6}$$

$$z = -\gamma|\dot{x}||z||z|^{n-1} - \beta\dot{x}|z|^n + A\dot{x} \tag{7}$$

x represents displacement of the damper piston rod; Damping coefficient c_0 is a constant. a represents the coefficients determined by the control system and the magneto rheological fluid. Through adjusting parameter, γ , β , A can unloading control force - speed curve of the linear traits and yield to yield after the transition smoothness.

The model can describe the relationship between force and displacement of MR damper, and the force velocity relation

curve is more close to the test result. Its outstanding characteristic is to fit the test result with the model which has smooth transition curve, easy to carry on the numerical calculation, the versatility is strong, can reflect all kinds of hysteresis curve, and has been widely used in the modeling of hysteretic system. But the model is still not well fitting damping force velocity relationship of nonlinear characteristics, fails to fit the inertial effect caused by low damping force attenuation phenomenon and the speed limit when the two clockwise hysteresis loop; and it is set up based on the test data of model, lack of unity and complex, not easy to use in actual engineering, only fit the experimental research and theoretical calculation.

3. MR Damper Design

Based on the analysis of the mechanical model of MR fluid damper, the Bouc-Wen model is adopted. The structure principle of MR fluid damper is shown in the following figure. The piston is wound with a coil to generate a magnetic field. Magneto rheological fluid flows through the damping channel between the piston and the cylinder wall, under the action of a magnetic field, MRF damping coefficient change, through the damping channel produce corresponding damping force.

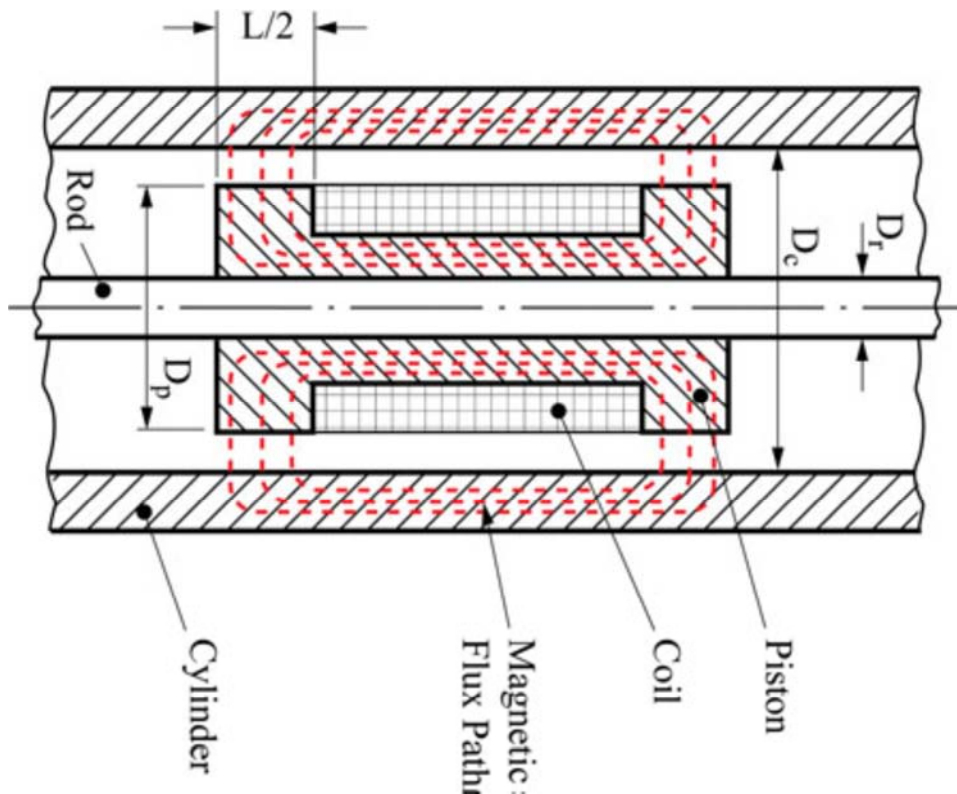

Fig. 5. MRF damping structure.

The structure design of MR fluid damper is mainly about the application of MR fluid damper.(such as the need to provide much of the damping force), then in combination with the specific use of the environment, the key parameters are the size of structure and affect the performance of the

design, so that the damper of the controllable damping force and damping force adjustable range can be achieved the desired effect.

Controllable damping force and damping force related to the performance of magnetorheological fluid damper quality,

as shown in the figure, the damping force of the damper by controllable damping force F_τ (also known as Coulomb damping force) and controllable damping force F_{uc} . The damping force of MR fluid damper is mainly controlled by the controllable damping force, and the value of the controllable damping force is generally 5-10 times of the uncontrollable damping force. Not controllable damping force F_{uc} by effect of magneto rheological fluid viscosity, flow velocity, mainly by the viscous damping force F_η and friction force F_f is composed.

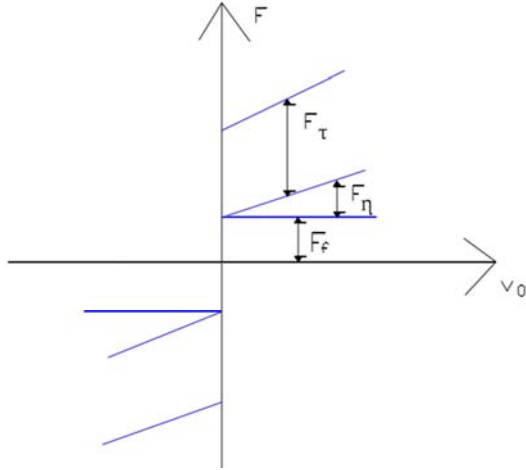

Fig. 6. Viscous damping force F_η and friction force F_f is composed.

MRF-damper viscous damping force F_η and Coulomb damping force F_τ respectively:

$$F_\eta = \left[\frac{3\pi\eta LA^2}{4D_c h^3} + \frac{L\pi D_c \eta}{h} \right] u(t) \quad (8)$$

$$F_\tau = \left[L\pi D_c + \frac{3LA}{h} \right] \tau_y \text{sgn}(u(t)) \quad (9)$$

A is cross-sectional area of the piston. $u(t)$ relative velocity of piston rod and cylinder; D_c is piston diameter; L is effective length of working area of magneto rheological fluid; h clearance between piston and cylinder; η dynamic viscosity of magneto rheological fluid; τ_y is magneto rheological fluid service.

The formula for calculating the total damping force of the MR fluid damper is:

$$F = \left[\frac{3\pi\eta LA^2}{4D_c h^3} + \frac{L\pi D_c \eta}{h} \right] u(t) + \left[L\pi D_c + \frac{3LA}{h} \right] \tau_y \text{sgn}(u(t)) \quad (10)$$

The first term in the formula (10) is related to the viscosity and flow rate of the magneto rheological fluid. The second one is the Coulomb damping force due to the change of the magnetic field, which reflects the special characteristics of the electronic control of the magnetorheological fluid damper.

The electronic control characteristics of MR fluid damper are mainly expressed by the yield stress of MR fluid.

$$\tau_y = KH^\beta \quad (11)$$

Among them, K and β are the experimental constants related to MR fluids, which are mainly related to the selection of the material. H as the magnetic field strength in the gap of the damper. The MR fluid damper is produced by American MRF-132D company load type magneto rheological fluid. The relationship between the yield stress and the magnetic field strength is shown in the following figure.

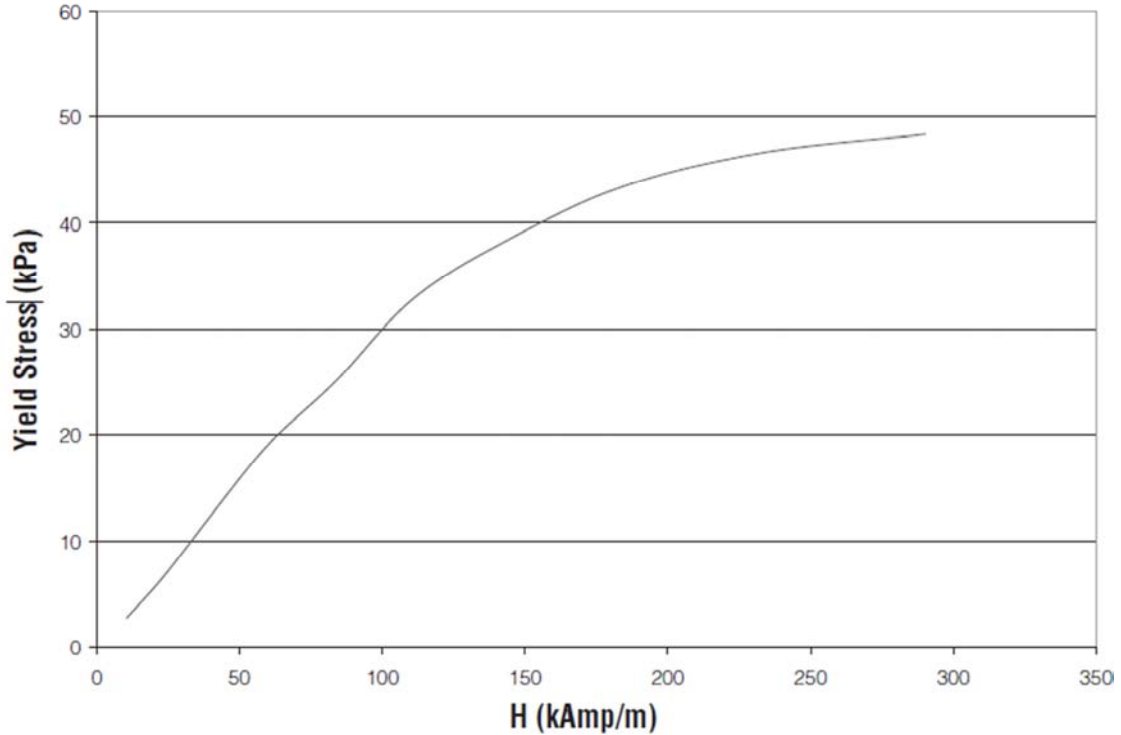

Fig. 7. Relationship between the yield stress and the magnetic field strength.

According to the above calculation and practical application, the parameters of MR fluid damper are determined as follows.

Table 1. Mr damper geometric and functional parameters.

Parameter	Symbol	Value
Cylinder Bore diameter	D_c	30 mm
Robe Diameter	D_r	10 mm
Psiton Diameter	D_p	27 mm
Active Piston Length	L	20 mm
Piston Gap	h	1.5 mm
Piston Effective stroke	L_s	60 mm

Three dimensional modeling of MR fluid damper is carried out by three dimensional simulation software, and the model is shown in Figure 7.

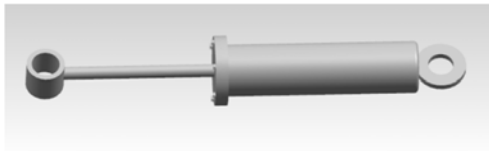

Fig. 8. MR fluid damper.

4. Conclusions

In this paper, the Bingham model of the magnetorheological fluid damper, the Bingham model, the model and the Bouc-Wen model are analyzed, and the mechanical model is selected according to the application situation. The three-dimensional model is established by the parameters of the calculation, which lays a foundation for the future mechanical simulation.

References

- [1] J.-M. Belda-Lois, A. Page, J.-M. B.-B. R. Poveda, and R. Barbera, *Rehabilitation Robotics: Biomechanical Constraints in the Design of Robotic Systems for Tremor Suppression*. Vienna, Austria: I-Tech Education and Publishing, 2007.
- [2] Ahmadian, M. and J. H. Koo, 2003, On the application of magneto-rheological dampers for reducing floor vibrations, *J. Acoust. Soc. Am.* 114, 2385-2385.
- [3] Zemp R. Tall building vibration control using a TM-MR damper assembly: experimental results and implementation. *Earthq Eng Struct Dynam* 2011; 40 (March): 257-71.
- [4] El-Aouar Walid H. Finite element based modeling of magnetorheological dampers, M.Sc. Thesis, Virginia Polytechnic Institute and State University, September 23, 2002.
- [5] Spencer Jr BF, Dyke SJ, Sain MK, Carlson JD. Phenomenological model of a magnetorheological damper. *J Eng Mech* 1997; 123: 230-8.
- [6] Butz T. Modelling and simulation of electro and magnetorheological fluid dampers. *ZAMM_ Z Angew Math Mech* 2002; 82 (1): 3-20.
- [7] Brigadnov LA. Mathematical modeling of magnetorheological fluids. *Contin Mech Thermodynam* 2005; 17: 29-42.
- [8] Costa Branco Costa. Continuum electromechanics of a magneorheological damper including the friction force effects. *Sens Actuat A, Phys* 2009; 155 (1): 82-8.
- [9] Chooi Oyadiji. Design, modelling and testing of magnetorheological (MR) dampers using analytical flow solutions. *Comp Struct* 2008; 86 (3-5): 473-82.
- [10] Tanner Beverly. Numerical analysis of extrudate swell in viscoelastic materials with yield stress. Department of Mechanical Engineering, University of Sydney, Sydney, NSW, Australia; 2006.
- [11] LORD Corporation. Lord Technical Data, MRF-132DG Magneto-Rheological Fluid. Cary, NC, USA; 2008.
- [12] Lorenz J, Fowler JT. Synchronous generator subtransient reactance prediction using transient circuit coupled electromagnetic analyses & odd periodic symmetry. In: *Proceedings of the 2006 International Ansys Conference*. Pittsburgh PA; 2006.
- [13] Schurter K, Roschke PN. Fuzzy modeling of a magnetorheological damper using ANFIS, 2001: 22-127. In: *Proceedings of the IEEE Fuzzy 2000 conference*. San Antonio, TX.
- [14] Yang B, Luo J, Dong L. Magnetic circuit FEM analysis and optimum design for MR damper. *Int J Appl Electromagnet Mech* 2010; 33: 207-16.
- [15] Dyke SJ, Spencer BF, Sain MK, Carlson JD. Modeling and control of magnetorheological dampers for seismic response reduction. *Smart Mater Struct* 1996; 5: 565-75.
- [16] Jolly MR, Bender JW, Carlson JD. Properties and applications of commercial magnetorheological fluids. *J Intell Mater Syst Struct* 1999; 10 (1): 5-13.
- [17] Lord Corporation. Designing with MR fluids; 1999 [engineering note].
- [18] Weber F. Bouc-Wen model-based real-time force tracking scheme for MR dampers. *Smart Mater Struct* 2013; 22: 045012.
- [19] Fujitani H, Sodeyama H, Tomura T, Hiwatashi T, Shiozaki Y, Hata K, et al. Development of 400 kN magnetorheological damper for a real base-isolated building. In: *Proceedings of SPIE* 2003, vol. 5052. p. 265-76.
- [20] Chae Y, Ricles JM, Sause R. Modeling of a large-scale magneto-rheological damper for seismic hazard mitigation. Part I: passive mode. *Earthq Eng Struct Dyn* 2012; doi: <http://dx.doi.org/10.1002/eqe.2237>.