Study on Force Characteristics of Buried Pipeline Under Impact Load Caused by Bridge Pile Foundation Construction

She Yanhua

School of Urban Construction, Yangtze University, Jingzhou, China

Email address:

syh916@126.com

To cite this article:

She Yanhua. Study on Force Characteristics of Buried Pipeline Under Impact Load Caused by Bridge Pile Foundation Construction. *American Journal of Mechanics and Applications*. Vol. 6, No. 2, 2018, pp. 62-67. doi: 10.11648/j.ajma.20180602.13

Received: August 8, 2018; **Accepted:** September 18, 2018; **Published:** October 18, 2018

Abstract: In the pile foundation construction of highway bridge, the impact hammer falls from a certain height, which produces a great impact when it collides with soil. In order to gain a clear idea of force characteristics of buried pipeline under impact load caused by bridge pile foundation construction, the effect of construction impacting load on buried pipeline is analyzed theoretically. Firstly, taking advantage of Boussinesq solution and Mindlin solution, the distribution of additional load on the surface of pipeline under impact load is analyzed, and the transmission and diffusion of impact force in soil are calculated by elastic half-space theory. Secondly, the mechanical models of buried pipeline under surface impacting and pile hole impacting are established respectively. Combined with Boussinesq equation, Mindlin calculation and infinite beam elastic foundation model, the calculation formula of buried pipeline under impact load is obtained. Finally, according to the formula established above, an example is given to calculate the additional bending moments and axial tension and compression stresses of buried pipeline caused by bridge pile foundation construction, so as to estimate the effect of construction impacting load on buried pipeline. The research results provide some guidance for the stress analysis of buried pipelines under such construction conditions.

Keywords: Buried Pipeline, Impacting Load, Pile Foundation Construction, Calculation Formula

1. Introduction

In highway construction, scholars put extra emphasis on the dynamic loads of buried pipelines, such as the ramming loads [1], rolling stone impact loads [2, 3], traffic loads [4, 5], blasting vibration loads [6, 7], which have been carried out on the effect of buried pipelines and many achievements have been made. However, the effect of impact load caused by bridge punching pile construction on adjacent buried pipelines is seldom studied, while it is very important to understand the influence of this kind of impact load put on the buried pipeline in practical engineering. Therefore, the force characteristics of buried pipeline under impact load caused by bridge pile foundation construction are studied.

In the bridge pile foundation punching construction, the hammer will fall from a certain height. When colliding with soil mass, the larger impact is produced. The influence of impact load on buried pipeline is through the transfer of soil

around the pipe and the interaction between pipe and soil, and finally acts on the pipeline in the form of soil pressure. In the analysis of mechanical properties of buried pipeline, it is assumed that the pipe is an infinitely long structure, only considering the joint action of the impact load and the soil pressure around the pipe, and ignoring the influence of internal pressure, construction defects, chemical corrosion, temperature changes and other ancillary structures on the buried pipeline.

2. Surface Additional Load Distribution of Buried Pipeline

The impact load has a strong instantaneous impacting force on the soil around the pipeline, resulting in additional loads on the pipeline. In the analysis of the additional load distribution on the pipe surface, the elastic half space theory is used to calculate the impacting force transmission and

diffusion in the soil.

Assuming that the soil is the uniform linear elastic infinite body, when a vertical concentrated force is acted on the surface of an elastic half space, the elastic solution of the stress and displacement caused by any point in the elastic half space is made by Boussinesq. As shown in Figure 1, the various stress components at any point in the half space are as follows[8, 9]:

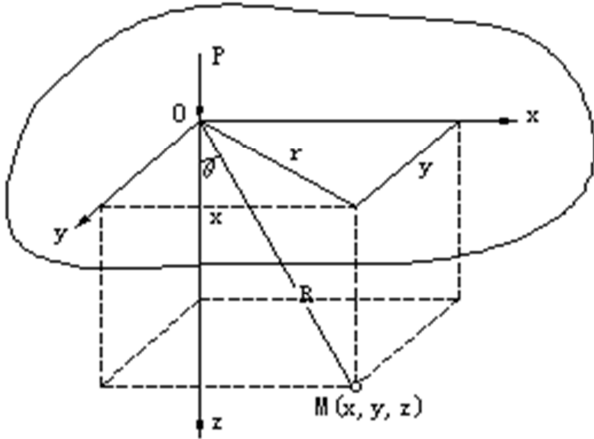

Figure 1. Force schematic diagram of arbitrary point in the elastic semi-space.

$$\sigma_x = \frac{3P}{2\pi} \left[\frac{x^2 z}{R^5} + \frac{1-2\nu}{3} \left(\frac{R^2 - Rz - z^2}{R^3(R+z)} - \frac{x^2(2R+z)}{R^3(R+z)^2} \right) \right] \quad (1)$$

$$\sigma_y = \frac{3P}{2\pi} \left[\frac{y^2 z}{R^5} + \frac{1-2\nu}{3} \left(\frac{R^2 - Rz - z^2}{R^3(R+z)} - \frac{y^2(2R+z)}{R^3(R+z)^2} \right) \right] \quad (2)$$

$$\sigma_z = \frac{3P}{2\pi} \frac{z^3}{R^5} = \frac{3P}{2\pi R^2} \cos^3 \theta \quad (3)$$

$$\tau_{xy} = \tau_{yx} = \frac{3P}{2\pi} \left[\frac{xyz}{R^5} - \frac{1-2\nu}{3} \frac{xy(2R+z)}{R^3(R+z)^2} \right] \quad (4)$$

$$\tau_{yz} = \tau_{zy} = \frac{3P}{2\pi} \frac{yz^2}{R^5} = \frac{3Py}{2\pi R^3} \cos^2 \theta \quad (5)$$

$$\tau_{zx} = \tau_{xz} = \frac{3P}{2\pi} \frac{xz^2}{R^5} = \frac{3Px}{2\pi R^3} \cos^2 \theta \quad (6)$$

In the above formula:

R —Distance from point M to point O,

$$R = \sqrt{x^2 + y^2 + z^2} = \sqrt{r^2 + z^2} = z/\cos \theta,$$

r —The horizontal distance between the point M and the point of concentrated force acting,

theta —The angle between the R line and the axis of the z coordinate,

E —Elastic modulus of foundation,

nu —Poisson ratio of foundation.

When the load of the surface action is distributed load, the Boussinesq solution can be used to calculate the stress and displacement of the distribution load on the arbitrary point in the elastic half space by the integral of the load distribution surface. Assuming a rectangular uniform load on the foundation, the coordinates of the load center are (x_p, y_p, z_p) and the border length are respectively l and b.

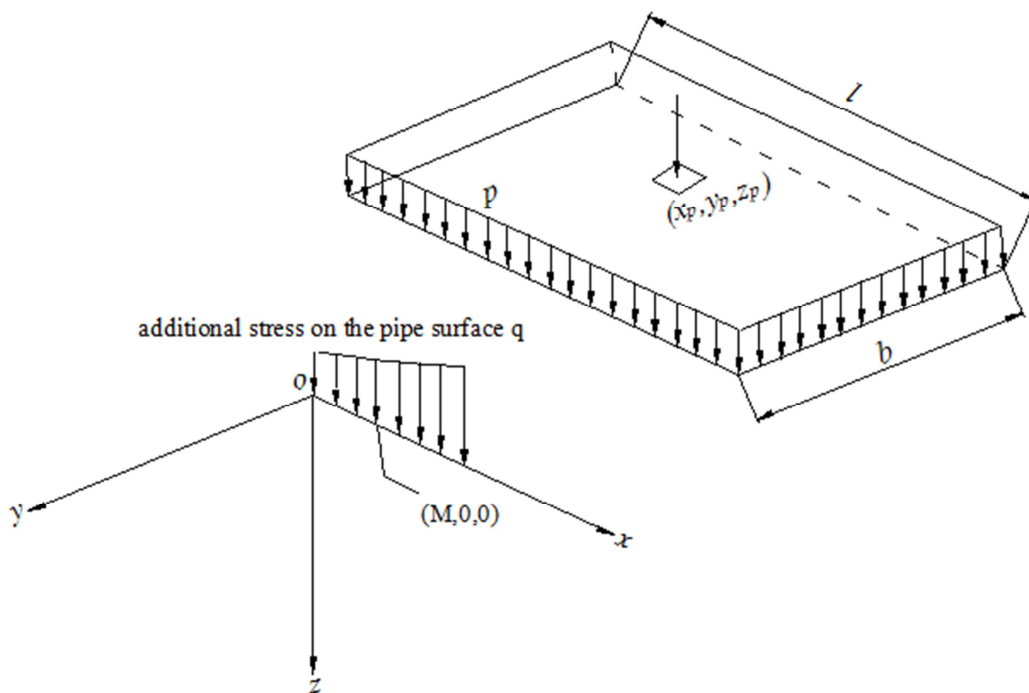

Figure 2. Schematic diagram of pipe force analysis.

As shown in Figure 2, the direction of the pipe length is x axis, the direction of the width is y axis, and the vertical direction is z axis (vertical downward direction is positive). The left end point of the pipe calculation section is the coordinate origin, and the coordinates of any point on the pipe are $(M, 0, 0)$. Then according to the above formula and coordinate transformation, the expression of vertical and

$$q_z = \frac{3z_p^3}{2\pi} \int_{y_p-0.5b}^{y_p+0.5b} \int_{x_p-0.5l}^{x_p+0.5l} \frac{P}{R^5} dx dy \quad (7)$$

$$q_y = \int_{y_p-0.5b}^{y_p+0.5b} \int_{x_p-0.5l}^{x_p+0.5l} \frac{P}{2\pi R^2} \left\{ \frac{3y^2 z_p}{R^3} + (1-2\nu) \left[\frac{R}{R+z_p} - \frac{z_p}{R} - \frac{y^2 (2R+z_p)}{R(R+z_p)^2} \right] \right\} dx dz \quad (8)$$

In the formula (7) and (8), $R^2 = (x-M)^2 + y_p^2 + z_p^2$

The displacements and stresses caused by horizontal concentrated forces acting on the interior of a semi-infinite body are proposed by Mindlin. The calculation model is shown in Figure 3. The horizontal stress expression at any point in the half-space caused by the force P along the x-axis (parallel to the half-space surface) is as follows[10]:

$$\sigma_x = \frac{Px}{8\pi(1-\mu)} \left(-\frac{1-2\mu}{R_1^3} + \frac{(1-2\mu)(5-4\mu)}{R_2^3} - \frac{3x^2}{R_1^5} - \frac{3(3-4\mu)x^2}{R_2^5} - \frac{4(1-\mu)(1-2\mu)}{R_2(R_2+z+h)^2} \right. \\ \left. + \frac{x^3(3R_2+z+h)}{R_2^2(R_2+z+h)} + \frac{6h}{R_2^2} (3h - (3-2\mu)(z+h) + \frac{5x^2 z}{R_2^2}) \right) \quad (9)$$

In the formula (9), μ —Poisson's ratio for soil medium, the meaning of other symbols is shown in Figure 3.

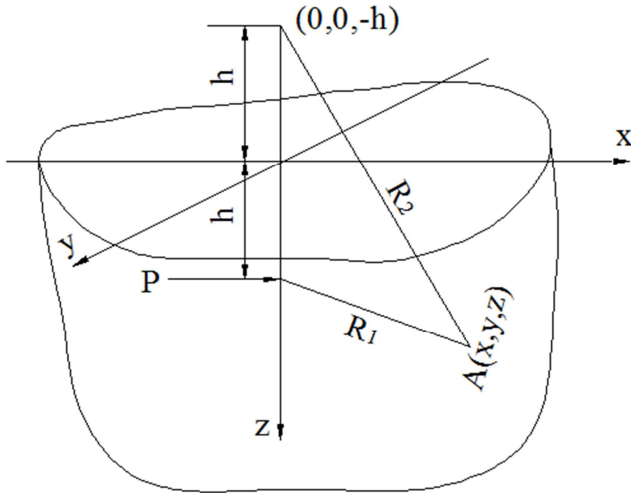

Figure 3. Calculation Model of Mindlin.

3. Surface Impact

Under the impact of hammer dropping, besides the impact on the surface, the stress on the pipeline is also the self weight stress of the upper soil, as shown in Figure 4.

horizontal additional loads on the surface pipeline can be obtained as follows:

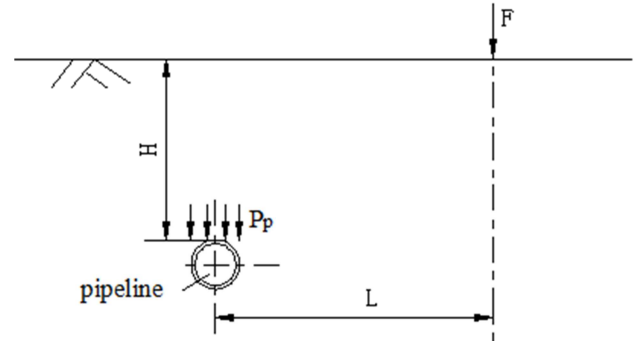

Figure 4. Mechanical analysis model of pipeline under impact loads.

The force of the impact on the pipeline can be calculated by the Boussinesq equation as follows[11]:

$$P_p = \frac{3F}{2\pi H^2 \left[1 + \left(\frac{L}{H} \right)^2 \right]^{2.5}} \quad (10)$$

In the formula (10):

P_p —The load impacted on the pipe,

F —Impact load on the surface,

H —Overlying layer thickness above pipe,

L —Horizontal distance between impact load point and the pipeline.

The force acted on the pipe is:

$$P_s = fP_p + P_v \quad (11)$$

In the formula (11):

P_v —the earth pressure above buried pipeline,

f' —penetration coefficient associated with the pipe buried depth[11], as shown in Table1.

Table 1. Penetration coefficient (f') versus buried depth.

buried depth (m)	0-0.3	0.3-0.6	0.6-0.9	>0.9
f'	1.5	1.35	1.35	1.15

4. Impacting in Pile Hole

4.1. Calculation of Soil Pressure Acting on Buried Pipe

Punching pile construction has great disturbance to strata. With the excavation of the pile hole, the hammer impacting on the soil causes the extrusion pressure around the pile hole wall. This horizontal extrusion pressure can be regarded as an internal force acting on a semi infinite body parallel to the x axis, and the two dimensional calculation model is shown in Figure 5.

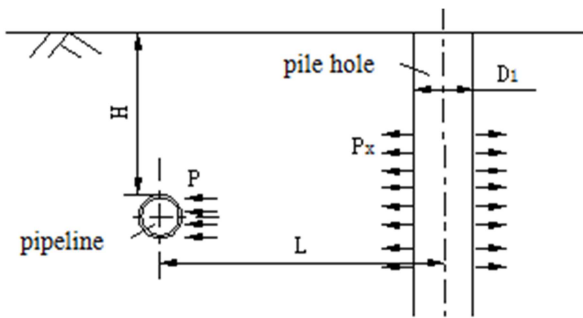

Figure 5. Model of punching construction effect on the pipeline.

It is assumed that the hammer impacting process is the process of pushing the soil of the same size into the soil layer without drainage. This causes large stress increment around the pile hole wall and it can be analyzed by the small hole expansion theory.

The elastic theory and Mohr-Coulomb failure criterion are used to analyze the following results[12]:

$$P_x = C_u \tag{12}$$

In the formula (12), C_u — the soil undrained strength.

The radius of plastic zone around the pile hole wall caused by hammer impacting is:

$$R = r \sqrt{\frac{E}{2(1 + \mu)C_u}} \tag{13}$$

In the formula (13):

E —soil elastic modulus,

μ —soil Poisson ratio,

r —The expansion hole radius, taken by the hammer radius.

In order to use the above Mindlin calculation model, P_x is converted into an equivalent concentrated force (considering 3 times the radius of plastic range), there is:

$$P = \frac{6r^2 E}{1 + \mu} \tag{14}$$

The P value is replaced into the formula (9), and the calculation parameters in formula (9) are as follows:

$R_1 = L - D_1 / 2$, $R_2 = \sqrt{(L - D_1 / 2)^2 + 4H^2}$, $z = H$, $x = L - D_1 / 2$. Then the maximum horizontal earth pressure σ_{max} acting on buried pipelines can be obtained.

4.2. Pipeline Stress Calculation

The soil pressure on the buried pipeline caused by the punching construction makes the pipe stress reach the maximum at the intersection point of the x and y axis, and with this point as the center, the pipe stress gradually decreases until zero.

The pipe is extruded and bent under the action of active pressure and produces tensile and compressive stresses along the axial direction. To determine the magnitude of this stress, it should first determine the buried pipeline stress.

Suppose that under the action $P(y)$, the reaction force on the buried pipeline is $q(y)$ and the friction between the upper and lower sides of the pipeline is f , as shown in Figure 6.

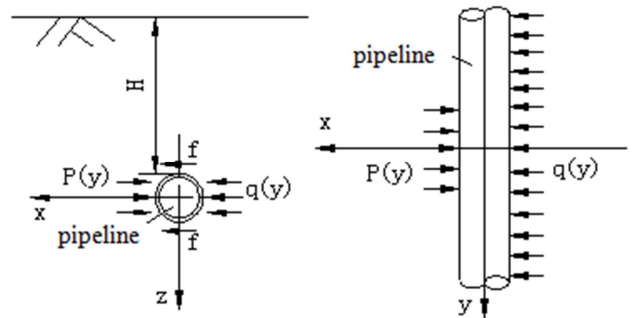

Figure 6. Force analysis model of pipeline.

Because the size of buried pipeline in the y axis is much larger than that in the x axis, it can be regarded as an infinite beam. If the deformation of the pipeline along the y direction is $w(x, y)$, then there is:

$$EI \frac{d^4 w(x, y)}{dy^4} = D(P(y) - f - q(y)) \tag{15}$$

In the formula (15):

E —Elasticity modulus of pipe material,

I — The moment of inertia of the pipe section,

$$I = \frac{\pi}{64} (D^4 - d^4),$$

D —The outer diameter,

d —inner diameter of the pipe.

Since the distribution of $P(y)$ is about X axisymmetric, it can be assumed to cosine function. If the force acting on the origin is P_0 and a is the length unit, then there is:

$$P(y) = \frac{2P_0}{\pi} \int_0^{\infty} \frac{1}{m} \sin(mD/a) \cos(my/a) dm \quad (16)$$

The formula (16) is substituted (6) to get the bending moment of any section of the pipeline, then

$$M(y) = -EI \frac{d^2 w(x,y)}{dy^2} = \frac{2(P_0 - f)}{\pi} \int_0^{\infty} \frac{\sin(mD/a) \cos(my/a)}{m^2 + \Omega} ma^2 dm \quad (17)$$

In the formula(17), Ω —dimensionless quantity, determined by different foundation models.

$$\text{For the Winkler foundation, } \Omega = \frac{ka^4 D}{EI},$$

$$\text{For the Pasternak foundation, } \Omega = (m^2 G_P + ka^2) \frac{a^2 D}{EI},$$

For the homogeneous isotropic foundation,

$$\Omega = \frac{E_s ma^3 D}{(1-\nu)EI}.$$

For simple calculation, the active pressure acting on the buried pipeline is equivalent to the concentrated force Q at the origin of coordinates. Then the bending moment of the buried pipeline can be obtained as follows[13]:

For the Winkler Foundation:

$$M(y) = \frac{Q-f}{4\beta} e^{-\beta y} (\cos \beta y - \sin \beta y) \quad (18)$$

In the above formula, β — a comprehensive parameter related to the elastic properties of pipe and foundation,

$$\beta = \sqrt[4]{\frac{kD}{4EI}}.$$

Then the maximum bending moment of the pipe section is

$$M_{\max} = \frac{Q-f}{4\beta} \quad (19)$$

For the two parameter model, there is:

$$M_{\max} = \frac{(Q-f)L^*}{4\alpha} \quad (20)$$

In the formula(20), $L^* = \sqrt[3]{\frac{2I(1-\nu^2)}{D}}$,

$$\alpha = \sqrt{\frac{S^2 + r^2}{2}}, S^2 = \frac{Dk(L^*)^4}{EI}, r^2 = \frac{DG_P(L^*)^2}{2EI}.$$

For homogeneous isotropic foundation model:

$$M_{\max} = 0.166(Q-f)D \left[16(1-\nu) \frac{EI}{E_s D^4} \right]^{0.277} \quad (21)$$

When M_{\max} is known, the tensile and compressive stresses on buried pipeline caused by punching pile construction can be calculated as follows:

$$\sigma_x = \frac{M_{\max}}{W} = \frac{32DM_{\max}}{\pi(D^4 - d^4)} \quad (22)$$

5. Example Analysis

Taking the impact drilling construction of bridge pile foundation of Rong-Wu expressway crossing Shaanxi-Beijing gas pipeline located Laiyuan as an example, the pipeline stress is analyzed. The diameter of punching hammer is 1.6m, the diameter of pile hole is 2m, and the horizontal distance between punching position and pipe center is 6m. The buried pipeline is a X60 grade steel pipe with the buried depth of 3m, outer diameter of 66cm, wall thickness of 8.7mm, and the modulus of 210GPa. The soil layer around the buried pipeline is sandy cobble soil, with deformation modulus of 10MPa and Poisson's ratio of 0.35.

According to the above method, the influence of the construction of the punching pile on the buried pipeline is estimated. The additional bending moment and the additional axial tension and pressure stress of the buried pipeline caused by punching pile construction are calculated as follows:

For the Winkler model: $M_{\max} = 4.63\text{kN}\cdot\text{m}$, $\sigma = 1.62\text{MPa}$.

For the double parameter model: $M_{\max} = 4.42\text{kN}\cdot\text{m}$, $\sigma = 1.55\text{MPa}$. For the homogeneous and isotropic elastic model: $M_{\max} = 4.21\text{kN}\cdot\text{m}$, $\sigma = 1.47\text{MPa}$.

From the above calculation results, it can be seen that the impact of punching pile construction on pipeline is not obvious for the steel buried pipeline with large tensile stress.

6. Conclusion

In this paper, the effect of impacting load caused by bridge pile foundation construction on buried pipeline is analyzed theoretically. The distribution of additional load on the surface of pipeline under impact load is expounded. Based on the Boussinesq equation, the stress expression of buried pipeline under the impact load of the ground surface is established. Based on the Mindlin calculation model and the model of the infinite beam elastic foundation, the calculation formula of the force of the buried pipeline under the impact load of the pile hole is established. And the influence of punching pile construction on buried pipeline is analyzed by taking a practical project as an example. The research results can be helpful for force theoretical analysis of buried pipelines.

Acknowledgements

This work is financially supported by National Natural Science Foundation of China (NSFC, 51408057) & Youth Talent Project of Yangtze University (2015cqr06).

References

- [1] Hang Chuanjun, Zhang Han, Zhang Jie et al., Journal of Safety Science and Technology, vol. 11, 2015, pp. 61-67.
- [2] Zhang Jie, Liang Zheng, Hang Chuanjun et al., Journal of Safety Science and Technology, vol. 7, 2015, pp. 11-17.
- [3] Xiong Jian, Deng Qinglu, Zhang Hongliang et al., Safety and Environmental Engineering, vol. 20, 2013, pp. 108-114.
- [4] Yang Guiling, Liu Kai, Wang Ming et al., Safety and Environmental Engineering, vol. 24, 2017, pp. 155-159.
- [5] Li Xinliang, Li Suzhen, Shen Yong-gang, Journal of Zhejiang University (Engineering Science Edition), vol. 48, 2014, pp. 1976-1982.
- [6] Zhong Dongwang, Huang Xiong, Si Jianfeng et al., Blasting, vol. 2, 2018, pp. 19-25.
- [7] Liu Xue tong, Zheng Shuang ying, Guo Dong dong et al., Pipeline Technique and Equipment, vol. 42, 2015, pp. 48-54.
- [8] Yu Xiaojuan, He Shan. Soil Mechanics and Foundation Engineering[M]. Beijing: Higher Education Press, 2018.
- [9] Kong Jun. Soil Mechanics and Foundation Engineering[M]. Beijing: China Electric Power Press, 2005.
- [10] R. D. Mindlin, Physics, vol. 7, 1936, pp. 195-202.
- [11] The American Society of Civil Engineers (ASCE). Guidelines for the design of buried steel pipe[S]. USA, 2005.
- [12] Hu Zhongxiong. Soil Mechanics and Environmental Soil Mechanics [M]. Shanghai: Tongji University Press, 1997.
- [13] Huang Yi, He Fangshe. A Beam, Plate, and Shell on an Elastic Foundation [M]. Beijing: Science Press, 2005.